

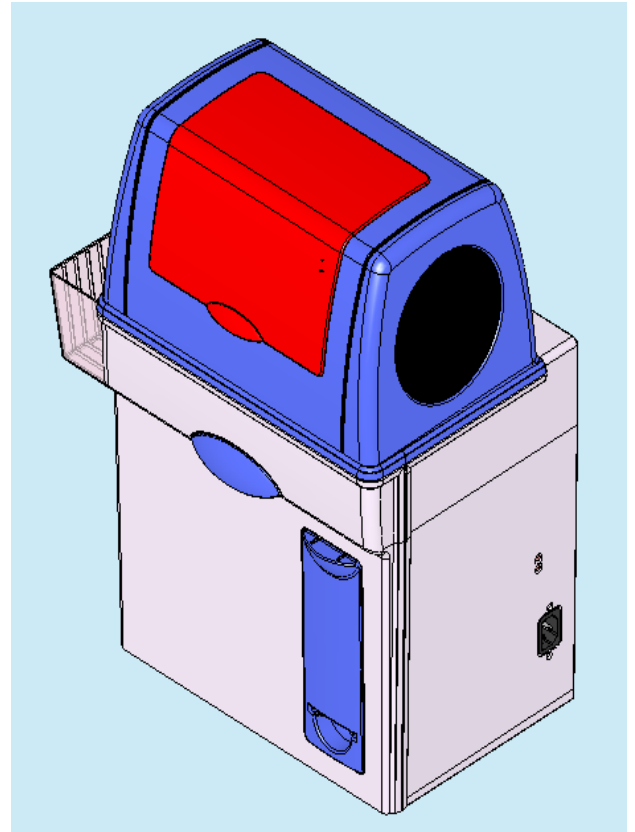

Automatic X-ray Film Processor

Installation,
Operation
And Maintenance
Manual



WARNING:

Do not plug into the electrical mains power supply before reading this manual – or before filling the machine with liquids



**Machine serial number to be quoted
on all correspondence**

MEDIVANCE INSTRUMENTS LTD.
Barretts Green Road • Harlesden
London • NW10 7AP • UK
Tel.: +44 (0)20 8965 2913
Fax: +44 (0)20 8963 1270

www.velopex.com

INTRODUCTION

Thank you for purchasing a Velopex SPRINT. This model is the simplest and most compact automatic x-ray processor we produce, and you will have no problem in finding a convenient site for installation.

Please read this manual carefully before plugging in and using your machine for the first time. Contained in this manual is information on the right place to position the Sprint, how to set up the machine correctly for use, and how it should be maintained so that you receive consistently high quality results over a long working lifetime.





INTRODUCTION TO THE PROCESSOR

The diagrams at the front of this manual are designed to introduce you visually to the layout of the Velopex SPRINT.

CONTENTS

	Page
TABLE OF SYMBOLS	4
TECHNICAL DESCRIPTION	5
SITING THE SPRINT	6
EXTERNAL FEATURES OF THE MACHINE	8
INTERNAL FEATURES OF THE MACHINE	9
WALL MOUNTING DIAGRAM	10
WALL MOUNTING INSTRUCTIONS	11
PREPARING TO USE THE SPRINT	12
Filling the Machine with Chemicals	12
OPERATING THE SPRINT	14
To Start	14
Processing Film	15
Film Collection	15
Each Day	15
FILM STORE	16
ROUTINE MAINTENANCE	16
Cleaning the Processor	16
Caution	17
TROUBLESHOOTING	18
Symptoms and Action	18
FILM QUALITY PROBLEMS	19
Films too dark	19
Films too light	20
Films dirty or marked	20
CONTAMINATION	21
USER SERVICEABLE ITEMS	21
MODULE DIAGRAM	22
SPARE PARTS	23
CONSUMABLE ITEMS	23
NON USER SERVICEABLE ITEMS	23

TABLE OF SYMBOLS

Symbol	Description
	Alternating current
	Dangerous voltage
	Caution, hot surface
	Attention, consult accompanying documents

This processor is fitted with indicator lights illuminated **RED**. When lit, these indicate that the processor is switched **ON** and operating correctly. In darkroom conditions, red illumination is used to prevent film fogging and, on this processor, it is **NOT** indicating a dangerous condition.

DISCONNECT MACHINE FROM THE MAINS ELECTRICAL SUPPLY WHEN IT IS NOT IN USE, OVERNIGHT AND WEEKENDS.

POSITION THE MACHINE TO ALLOW EASY DISCONNECTION FROM ELECTRICAL SUPPLY.

Input rating:

110–120V, 200–240V ~ 50 – 60 Hz – Power Input 200w
This equipment must be plugged into an earthed/grounded socket outlet.
Use only the connection lead supplied.

TECHNICAL DESCRIPTION

The Velopex "Sprint" X-Ray Processor is a machine for developing and fixing dental x-ray films without user contact between insertion of the exposed film and receipt of the developed film into the wash-tank for collection at the end of the process.

The machine receives undeveloped film in a light-tight enclosed area, visible through its protective red perspex flap, where a motor-driven "module" carries it between two continuous belts through a tank containing Developer. The film is passed out into an identical "module" working in a second tank, containing Fixer.

Chemical temperature is maintained at 27°C, (81°F), by two rod heaters protruding from the rear wall of the machine, heating each chemical tank through a metal sleeve.

The film finally passes into a water Wash Tank after processing. It is retrieved by removing the film from the collector tank.

The overall dimensions of the processor are:– width 380mm (15 inches), with water tank fitted; height 450mm (17¾ inches); depth 230mm (9 inches).

The weight of the processor is: empty, 6.85 kg (15 lb); full, 10.25 kg (22½ lb).

This machine is a CLASS I device.

ENVIRONMENTAL CONDITIONS FOR TRANSPORT AND STORAGE

This machine should be kept within the temperature range –10°C and +40°C, (14°F and 104°F) and below 80% humidity.

INTERFERENCE BETWEEN EQUIPMENT

This X-Ray processor complies with the following E.M.C. Standards

E.E.C– EN60601-1-2

U.L– FCCPart 15 Class A

In the event that electromagnetic or other interference is suspected between this processor and other equipment close to it, move the two units further apart until the problem is eliminated.

SITING THE SPRINT

PRE-INSTALLATION INSTRUCTIONS

Although the Velopex Sprint is designed for use in daylight, care should be taken to avoid sources of intense light. For example do not site directly under a window, fluorescent tube or floodlight.

A well ventilated position is mandatory.

The SPRINT has been designed for use on a normal counter-top or for wall-mounting. It is important that when the machine is filled with solution the stand does not rock or shake, as this could cause spillage. **Never** move the machine with chemicals in the tanks.

Avoid siting the machine above or near other electrical, mechanical or sensitive apparatus – e.g. autoclave, compressor, evacuation equipment.

Place the machine against a wall to prevent it from being accidentally knocked over.

The machine should not be placed in areas exposed to flammable gases.

When the machine is to be sited in a darkroom, it is essential to ensure that the room is well ventilated and light-tight. There should be sufficient space for easy chemical changes and for the machine to be serviced safely.

When choosing a site for your Velopex it may be convenient to site the machine near a sink for ease of chemical changing.

When choosing the site, it is important to allow for the presence of liquids. Surfaces susceptible to water (or chemical) damage should therefore be avoided. Avoid carpeted areas.

The ambient temperature must be maintained below 27°C (81°F).

WARNING: X-ray radiation can be harmful to patient, technician and dentist. Inadequate lead shielding of the darkroom or film storage area will also cause fogging of films from exposure to stray x-ray radiation.

Consult your Radiation Protection Adviser, your local bye-laws, your Department of Health and Safety or Dental Equipment Dealer for

proper construction of darkroom or placement of film processing equipment in the vicinity of x-ray radiation sources.

CLEANING THE PROCESSOR CASING

Keep the outside of the machine clean with a mild solution of household detergent and warm water (not boiling).

Use a damp cloth only (wring all excess water out of the cloth) and wipe the external surfaces, exercising extreme care around the electrical components.

WARNING: Ensure that the machine is disconnected from the mains power supply during cleaning and never allow water to seep into the casing.

EXTERNAL FEATURES

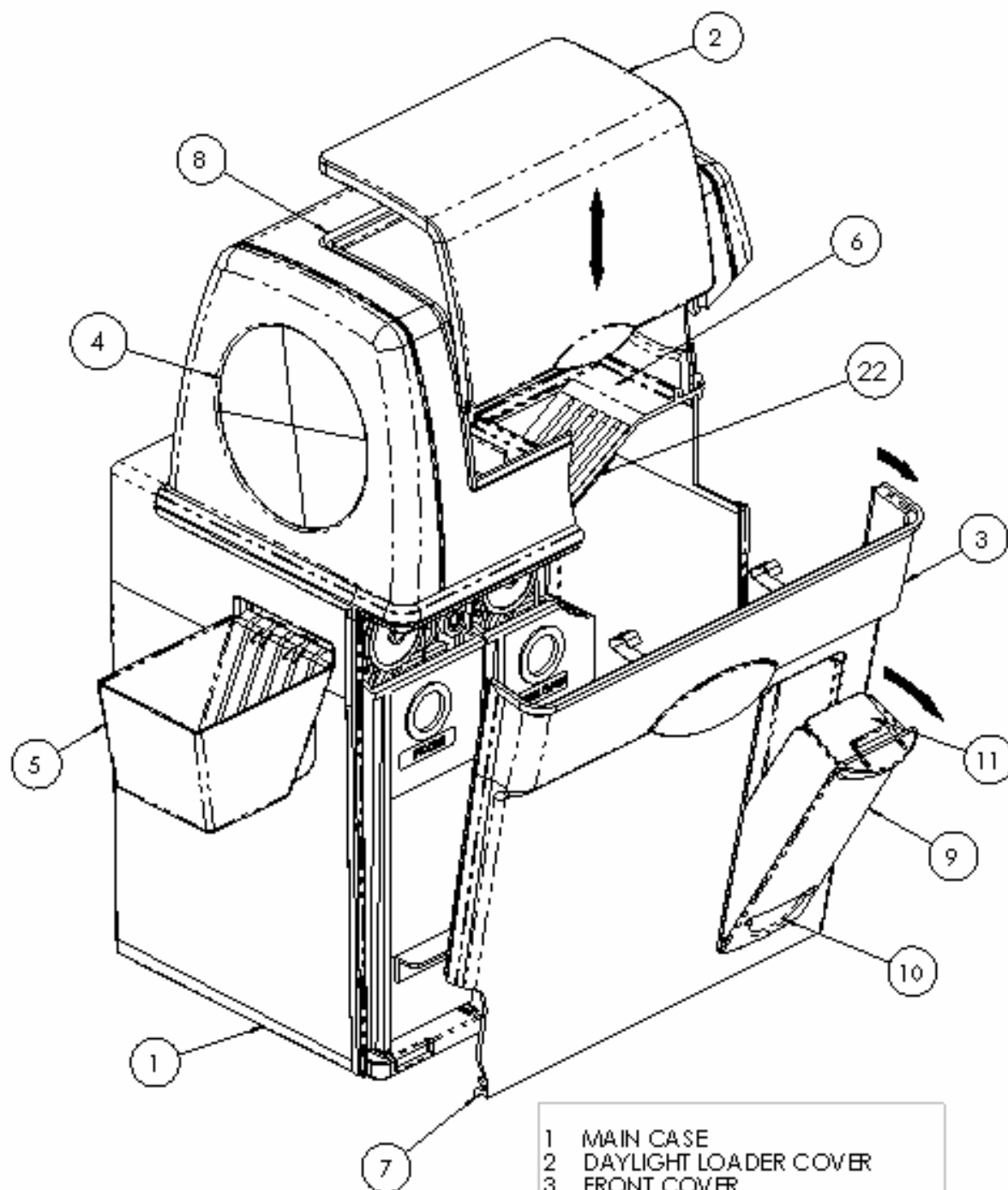

- 1 MAIN CASE
- 2 DAYLIGHT LOADER COVER
- 3 FRONT COVER
- 4 HAND ENTRY PORT
- 5 WASH TANK
- 6 FILM ENTRY CHUTE
- 7 FRONT COVER LOCATING LUGS
- 8 DAYLIGHT LOADER COVER RETAINING CHANNEL
- 9 FILM STORE
- 10 FILM DISPENSER
- 11 FILMS
- 22 INITIATION SENSOR

INTERNAL FEATURES

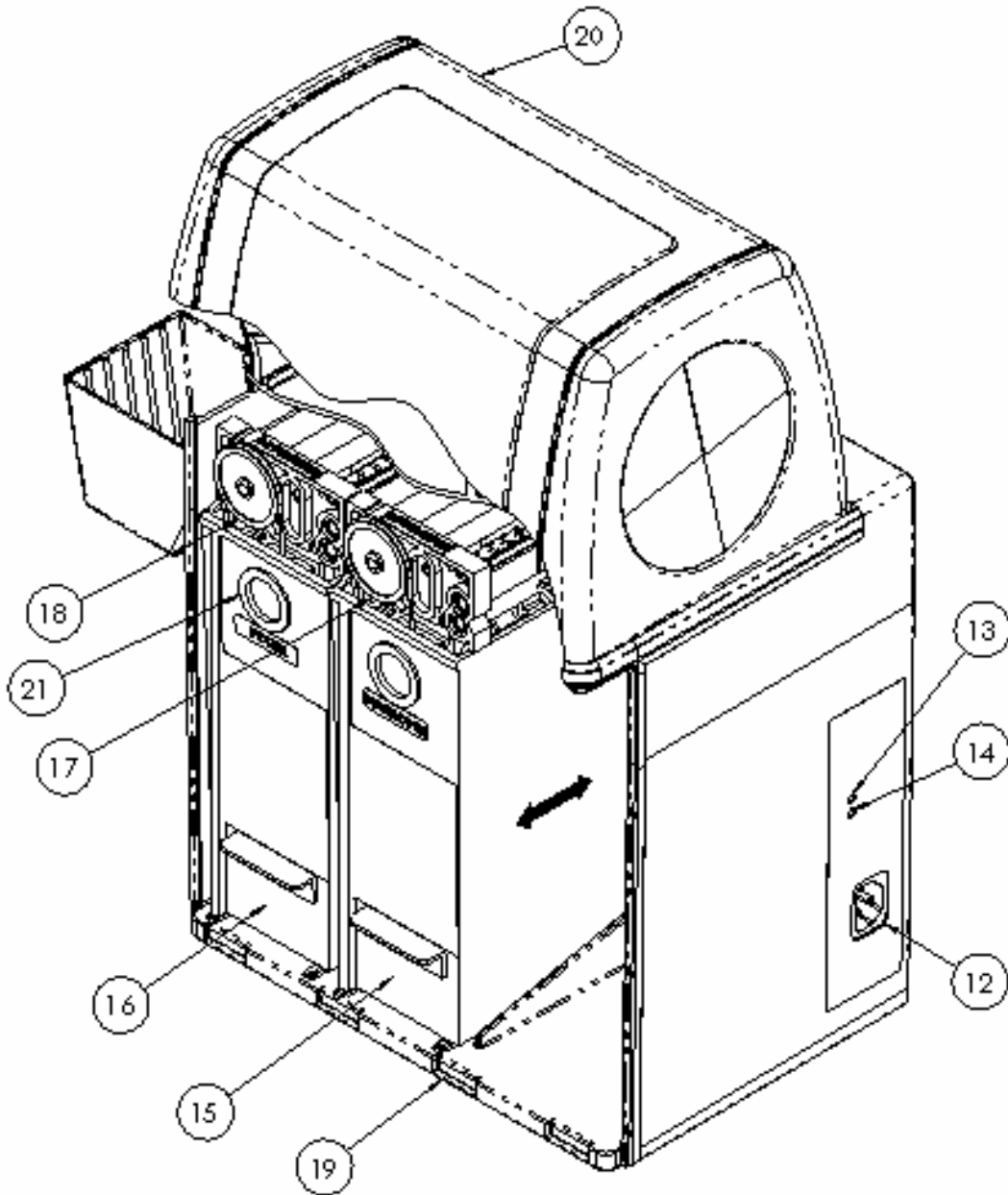

- | | |
|----|----------------------------|
| 12 | MAINS INLET SOCKET |
| 13 | MAINS INDICATOR LAMP |
| 14 | HEATER INDICATOR LIGHT |
| 15 | DEVELOPER TANK |
| 16 | FIXER TANK |
| 17 | DEVELOPER MODULE |
| 18 | FIXER MODULE |
| 19 | FRONT COVER LOCATION SLOTS |
| 20 | DAYLIGHT LOADER |
| 21 | LIQUID LEVEL WINDOW |

WALL MOUNTING DIAGRAM

WALL MOUNTING CENTRES

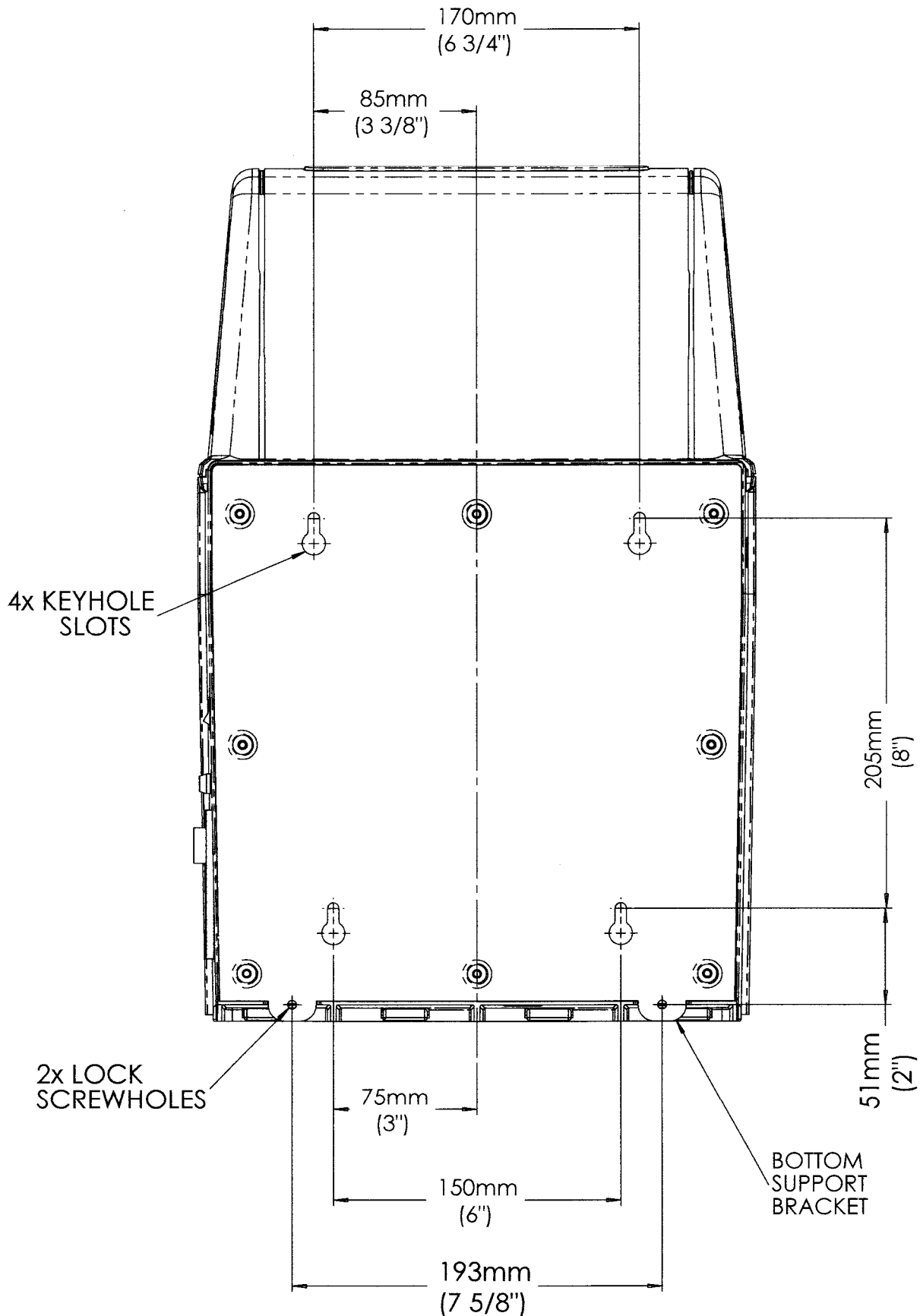

WALL MOUNTING INSTRUCTIONS

The Sprint is ideal for wall mounting and is fitted with 4 keyhole slots on the rear panel. A further 2 locking holes at the bottom of the rear panel prevent accidental lifting once in place.

Choose an area of wall that is both flat and vertical. It must be able to carry a load of 25kg, (55 lb). Use all the mounting points to ensure a secure fixing and to spread the loading onto all the screws.

NOTE: - Please remember to position the processor within 1 metre, (3 feet), of the electrical supply, preferably with the supply socket to the right of the machine.

1. Use screws and wall anchors suitable for the type of wall.
2. Using the template provided, hold in the required position on the wall and temporarily fix using suitable adhesive tape. Use a spirit level and adjust as necessary.
3. Using suitable wall plugs for the type of wall proceed as follows:-
 - Drill 4 holes in the wall for the keyhole slot screws – To suit No 12 x 35mm (1½ inch) Pan Head slotted screw.
 - Drill 2 holes in the wall for the lower locking screws – To suit No 8 x 25mm (1 inch) Pan Head slotted screw.
4. Place all the wall plugs into their appropriate holes.
5. Fit the 4 keyhole screws into position leaving the screw heads 3mm, ($\frac{3}{8}$ inch), proud of the wall surface.
6. Lift the **EMPTY** processor up to the wall and using the keyhole slots, hook the machine onto the 4 screws. If necessary, adjust the screw head heights if they appear too tight or loose.
7. **IMPORTANT:** - Lock the machine into position by assembling the two remaining screws into the lower fixing holes.
8. Test that the machine is mounted correctly by checking that it cannot now be lifted off the wall.

PREPARING TO USE THE SPRINT

The machine is supplied in a single carton containing:-

Velopex SPRINT Processor; Operator's Manual; Water tank; Machine Accessory bag containing: - Electric Lead; Transport Module Turning Tool; Cleaning Brush; Chemical Change Chart and Warranty Card.

1. Familiarise yourself with the layout of the machine by referring to illustrations at the front of this manual.
2. Remove the water tank and Film accessory bag that are stored inside the daylight loader, (item 20). Entry into the Daylight Loader is made by vertically lifting the daylight loader cover, (item 2).
3. When the machine has been unpacked and is in position, the inner packaging must be removed. The transport modules inside are protected by internal packing pieces. Open the front cover (item 3) and discard the packaging along with the separating sheet between the output rollers of both modules (items 17 and 18).

FILLING THE MACHINE WITH CHEMICALS

WARNING: Ensure the machine is disconnected from the mains power supply when filling with chemicals and water. NEVER turn on the machine with the tanks empty. Hot parts are exposed when removing the tanks. SWITCH OFF THE MAINS SUPPLY.

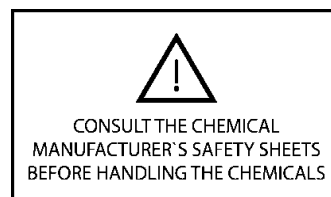

Do not use chemistry or film designed for manual processing.

Note: Optimum processor performance will be achieved by using Velopex Fixer and Developer. The machine is built, however, to work satisfactorily using most high quality brands of chemical.

ONLY use chemicals designed for automatic processing. Chemicals used for MANUAL PROCESSING ("hand dunking") will produce poor results.

1. The correct positions for the tanks are clearly marked.
2. Each tank with its transport module in place should be withdrawn:
NOTE: This is done by sliding FORWARDS (towards the operator) until completely clear of its rod heater element fixed to the machine internal back wall. The Developer tank is removed first; the Fixer tank second. Do not lift either tank until it is clear of the front of the

machine.

3. Tanks are now free to be taken to a clean working surface for filling.
4. The transport modules should now be lifted from their respective tanks and the separating sheets removed from between the output rollers.
5. Start to fill each tank with the appropriate chemical, pouring in 1(one) litre fluid at this stage. Pour in accordance with the marking on the tanks, i.e. Developer always in the Developer tank and Fixer in the Fix tank.
6. The rod heating elements fixed to the internal wall of the machine must be lightly lubricated **only** with the silicone grease provided. (Replacement tube Pt. No. I/FIT5041P) Use at first time of operation and after every tank removal.
7. Carefully lower each transport module into its respective tank – **NOTE**, rapid immersion will cause excessive displacement of chemical leading to spillage.
Should any spillage occur it should be cleaned up immediately.
8. The level of the liquids should now be adjusted: – top up to within 25mm, (1inch), from top of the tank, (shown as half way in the tank viewing window, item 21). This level should be checked every day and topped up as necessary.

IMPORTANT: When returning the transport modules to their tanks, ensure that they are correctly positioned, i.e. with the drive pins inwards so that they engage correctly with the drive dogs on the inside wall of the tank area.

9. Return tanks to their individual positions in the machine (clearly marked), –
N.B. Fixer first, Developer second. Push the tanks carefully home until they touch the rear wall of the tank area, ensuring that each drive pin engages its drive dog.
10. Load the film store (item 9) if required.
11. Replace the front cover by dropping its locating lugs (item 7) into the front cover locating slots (item 19). Now close the front cover until it clips shut.

WARNING: If the front cover will not close fully, remove it and make sure that both the tanks touch the rear wall of the tank area and the modules are fully engaged in the drive dogs.

12. Gently replace the red daylight loader cover, (item 2), by lowering it vertically until it engages fully into both front and rear retaining channels (item 8) in the Daylight Loader (item20).

WARNING: If the red cover is not fully in position the unit will not be light-tight, and film fogging will occur.

13. The wash tank (item 5) should now be filled with water to the "level" line and hung in position on the left hand side of the main case, at the film exit slot.

OPERATING THE SPRINT

TO START

NOTE: - Ensure that the two tanks are correctly filled with chemicals and fitted into position before switching on the machine.

First plug the electric power lead into the socket (item 12) on the right hand side of the processor and plug the other end into the mains wall socket. The processor may now be switched on by the wall socket switch. The machine has 2 modes of operating. Whilst the chemistry is below the correct temperature (Indicator lights are flashing), temperature will be sensed and the speed will be adjusted accordingly. When the temperature of the chemistry reaches 27°C the machine can operate in 2 modes: Normal Speed – this is indicated by a single ‘Bleep’ on initiation – the film spends approximately 1 minute in each chemistry tank. Fast Speed – this is indicated by 2 ‘Bleeps’ on initiation (Finger has to be left longer over initiation sensor) – the film will travel through the chemistry tanks at double the speed of Normal speed. At the end of the cycle the speed will default back to Normal.

PROCESSING FILM

Push hands, (with the exposed film package) through the hand entry ports (item 4) at each end of the Daylight Loader (item 20). Strip the film from its wrapper. Hold one of your hands on the Film Entry Chute (Item 6).

Listen to select the speed: 1 Beep–Normal, 2 Beeps–Fast (if the operating temperature is at optimum). When the correct speed is sounded remove the hand, and slide the film carefully down the Film Entry Chute. The film should be picked up by the transport mechanism.

As soon as each film has fully entered the transport, you may begin processing the next film.

IMPORTANT: Do not remove hands from the loader until the last film has entered the transport system. To do so may cause film fogging.

FILM COLLECTION

An audible Beep will sound when all the films entered are processed. Films will collect in the Wash Tank and may be lifted clear by hand. Films should be separated before drying to avoid sticking together. Change the water in the Wash Tank every five films processed.

EACH DAY

1. Before use check levels of Developer and Fixer and top up where appropriate.
2. Before processing run through a 'clean-up' film. This may be done during the warming up period. For clean-up films use a spare intra-oral film. After a week discard the old film and use a fresh one. This routine helps to clean the transport system and checks that the transport mechanism is running properly.
3. Renew the water in the wash tank.
4. At the end of the day turn the Mains Power Switch OFF and disconnect machine.

WARNING: Turning off electrically at the end of each workday is an essential safety procedure.

POSITION THE MACHINE TO ALLOW EASY DISCONNECTION FROM ELECTRICAL SUPPLY.

FILM STORE

The SPRINT is fitted with a simple film store and dispenser drawer for standard intra-oral film (item 9).

To load the film store, unclip the top from the front cover and remove.

Stack new film neatly into the back of the film store (item 11) as illustrated, uniformly orienting in one direction.

Return the film store back into position and clip the top into place.

Films are simply dispensed by placing the index finger through the U-shaped dispenser hole (item 10) on the outside of the cabinet, and gently easing them out.

NOTE: The film store must always be in position, even if empty or not being used, otherwise light will leak into the processing area and will fog the films being processed.

ROUTINE MAINTENANCE

CLEANING THE PROCESSOR MODULES

A clean processor is the key to consistent good results and the following cleaning routine

should be carried out at each chemical change – the frequency will vary according to the use of the machine and the number of x-ray films passed through it.

Regularly inspect the supply cord for any damage, at least every time the machine is cleaned. Replace if necessary.

NOTE: It is not recommended to extend the use of chemicals beyond three weeks.

1. Switch off the processor and disconnect it from the mains power supply.
2. Place transport modules in a sink with running water and a drain. Rinse under the running water.

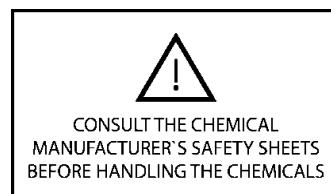

Do not allow chemicals to dry on the belts before cleaning.

NOTE: the modules will be wet with chemicals – take care to allow them to drain a little over the tanks before moving them.

3. Clean tanks first by rinsing the insides with fresh, running water, and allow draining. Wipe dry inside and out before re-filling.
4. Clean transport modules thoroughly one at a time with fresh water for each module to avoid cross-contamination. Take care to return each to the tank from which it has been removed, e.g. Developer module to Developer tank.
5. The best method of cleaning a module is to immerse totally in a sink full of hot water (not boiling). Using the brush provided, scrub around the gears and the roller ends. Using the special tool provided, rotate the gears and belts by hand to assist in thorough cleaning. (Rinse the belts thoroughly – Do not use detergents, just hot water.)

Never use boiling water; boiling water will damage your module.

6. After cleaning, pour 1 litre (1¼ pints) of fresh chemical into the correct tanks and replace the modules into their respective tanks. Top up the chemicals to within 25mm (1 inch) of the top of the tanks. Renew the silicone grease on the heating elements. Replace the tanks in the processor, fixer first, followed by the developer.
7. Be sure to keep a note of the date when chemicals are changed, using the chart provided.

PLEASE NOTE: Spend time cleaning the machine, as you will be amply rewarded by high quality results and extended chemical and machine life.

CAUTION: Processing chemicals should be handled with care. If spilt they may cause staining or corrosion of surfaces. They can also cause skin or eye irritation - wipe up any drips or spillage immediately. If chemicals are splashed onto the skin or eyes, flush immediately with abundant amounts of plain water. Always observe the chemical manufacturer's recommendation for this situation. Problems of this nature can be avoided by wearing protective glasses and gloves.

TROUBLESHOOTING

SYMPTOMS AND ACTION

Symptom: Machine does not operate.

- Action:**
1. Check that Mains Power is plugged in and the supply is switched on.
 2. Check that cord is fully engaged in both mains power supply and socket on the right hand side of the machine.
 3. Switch off Mains Power supply and unplug the machine and call for Service.

Symptom: Heater Indicator Light Permanently Off and Audible Bleep

Action: Light is constantly off with an audible bleep– the machine has detected a function out of limits. Call for Service.

Note: After 30 minutes the audible bleep will stop but the Heater Indicator Light will remain off.

Symptom: Chemical(s) overheating.

Action: 1. Call for Service.

Symptom: Films will not enter through Film Entry Guide.

Action: 1. Open machine Daylight Loader Cover and Front Cover and check correct engagement of transport modules.

Symptom: Film Lost in the Machine.

- Action:**
1. Check that the transport modules are correctly located in their drive dogs and running correctly. If not, re-locate.
 2. Check the spring tensioning of the modules and check for correct positioning. Use the module turning tool to rotate the belts for inspection, and run a test film through the module using this tool.
 3. Check that transport modules have been put through the correct cleaning procedure.
 4. Should there be any damage to the belts, such as tearing or twisting, order a replacement module.

FILM QUALITY PROBLEMS

SYMPTOMS AND ACTION

Symptom: Films too dark or fogged.

- Action:**
1. Test for light fogging by feeding an unexposed film through the machine. It should process as a transparent piece of film base with no signs of shadows or blackness evident.

 2. If there is light fogging, proceed as follows:–
 - a) Check that the daylight loader cover is firmly in place.
 - b) Check very closely for other possible light leaks: ensure that the machine has not been sited in direct sunlight or in intense lighting conditions (e.g. directly under strip lights or spotlights). Do not take your hands out of the daylight loader before the film has fed completely into the machine.
(Fog at one end only of the film indicates premature removal of hands from daylight loader).
Check hand entry ports to ensure there is a good light seal around the wrists –if not, call for service.
 - c) Check whether films have been stored too close to x-ray source, and re-locate.
 - d) Check expiry date on film box to ensure films are not out of date. (Keep films in a cool, dry place: excessive heat can cause premature ageing of film).

 3. Check that there has been no chemical mix-up, leading to cross-contamination.

 4. Check temperature of developer and fixer tanks. This is generally set at 27°C (81 °F). A substantial difference could lead to dark film. Switch off the machine and call for service.

Symptom: Films too light.

- Action:**
1. Check chemicals as follows:
 - a) Chemicals exhausted – replace with fresh.
 - b) Chemicals contaminated – clean machine, replace chemicals with fresh solutions.
 - c) Chemical level in tanks too low – top up.
 - d) Temperature of chemical(s) too low, (check with a thermometer) – below 27°C (81 °F) – call for service.
 2. Check films have been exposed correctly.

Symptom: Films dirty or marked.

- Action:**
1. Check water. Clean tank thoroughly and change water.
 2. Check transport modules are being cleaned correctly (see cleaning instructions).
 3. Check chemical level in both tanks and top up as required.
 4. Check modules for correct positioning. When found in incorrect order, contamination will have occurred. Thoroughly wash and replace with fresh chemicals.
 5. Check for stray light entering machine – proceed as for fogging (see above).

CONTAMINATION

When changing chemicals, make sure that the tanks are emptied completely and rinsed out. Fresh chemical will be spoiled by contamination, leading to poor results.

WARNING: If the unit should emit abnormal odour, become overheated in some parts or produce unusual noises, unplug from Main Power Supply. Contact your Velopex supplier.

A clean, well-maintained machine will produce good clear x-rays; a dirty machine will cause problems.

Do not struggle with film processing problems. Through experience, MEDIVANCE INSTRUMENTS probably has the answer.

USER SERVICEABLE ITEMS

CAUTION

PLEASE NOTE: THERE ARE NO USER SERVICEABLE ITEMS WITHIN THE ELECTRICAL COMPARTMENT OF THE MACHINE

MODULE GEARS

If problems are experienced with the transport module it should be considered for replacement.

However changing of the gears is an extremely simple operation and can be carried out on site. To replace gears proceed as follows:-

Remove gear cover plate retaining screw, see diagram on next page, (item 22). The gear cover plate (item 23) can now be gently eased off. Remove old gears and replace with new gears to their correct positions. Replace gear cover plate and retaining screw.

Module Diagram

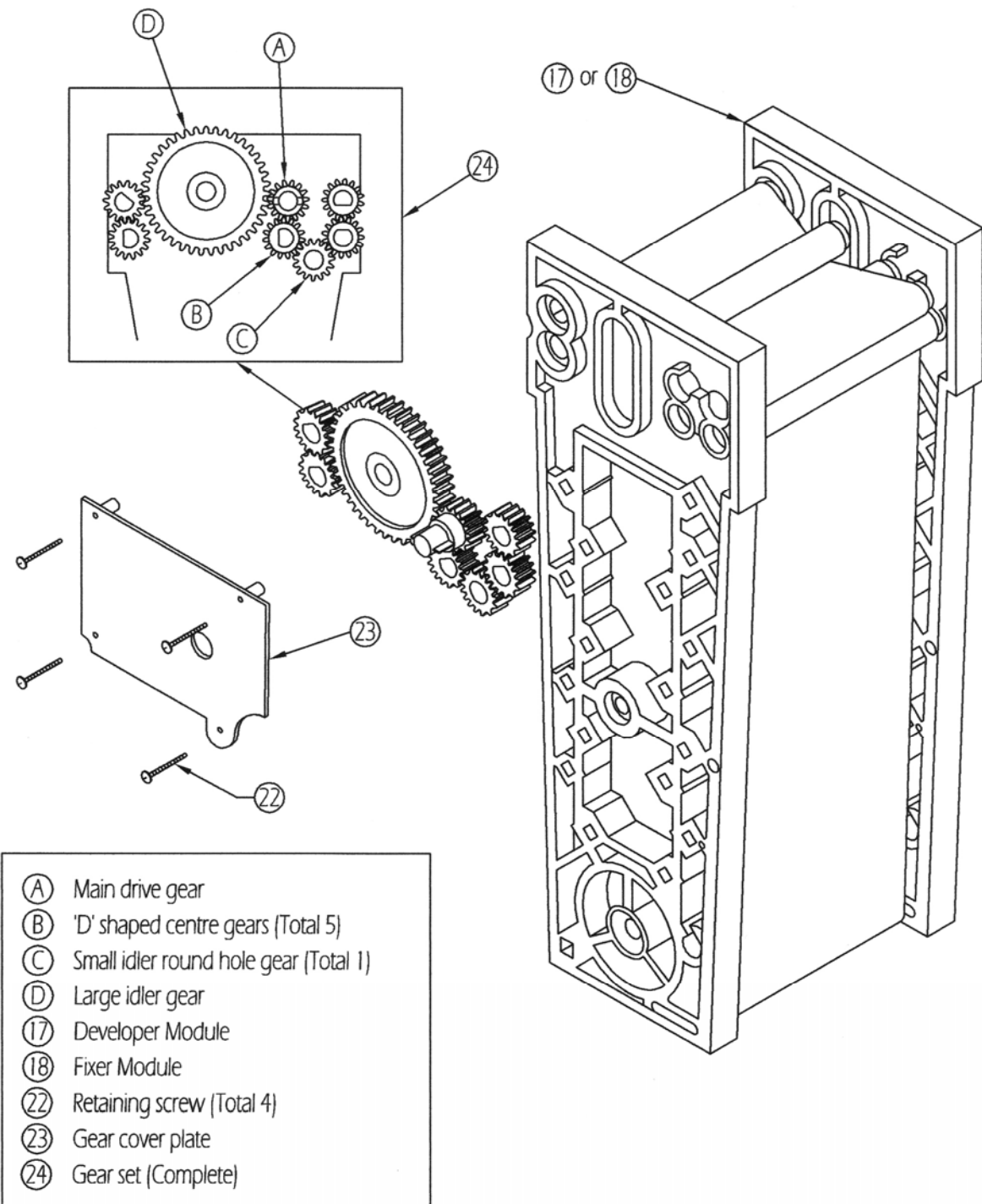

SPARE PARTS

<u>ITEM No</u>	<u>Description</u>	<u>Part No</u>
2	Daylight Loader Cover	I/MDG7708P
4	Hand Entry Ports (2 off)	I/ASS7710A
5	Wash Tank Assembly	I/ASS7713A
15	Developer Tank	I/MDG2176F
16	Fixer Tank	I/MDG2177F
17	Developer Module	I/MOD0067F
18	Fixer Module	I/MOD0068F
Page 24	Module Gear Replacement set	I/MOD0100F

CONSUMABLE ITEMS

Chemistry	Developer Ready-To-Use	(2x5 Ltr)	C/DER3001F
	Fixer Ready-To-Use	(2x5 Ltr)	C/FIR5000F
Film	Intra-Oral D Speed	(4x25)	I/FLM7000F
	Intra-Oral E Speed	(4x25)	I/FLM7001F
Quality Control	Vischeck	(20 Strips)	I/FLM7002F
	System Cleaner Tablets	(36)	I/TAB0002P

NON USER SERVICEABLE ITEMS

Medivance Instruments will make available on request circuit diagrams, component part lists, descriptions, calibration instructions, or other information which will assist the user's appropriately qualified technical personnel to repair those parts of equipment which are designated by Medivance Instruments as repairable.

Application should be made to:

Medivance Instruments Limited
Service Department
Barretts Green Road,
Harlesden
London NW10 7AP

Tel: - +44 (0)20 8965 2913

Fax: - +44 (0)20 8963 1270



MEDIVANCE INSTRUMENTS LTD.

Barretts Green Road • Harlesden

London • NW10 7AP • UK

Tel.: +44 (0)20 8965 2913

Fax.: +44 (0)20 8963 1270

www.velopex.com

105 East 17th Street

Saint Cloud • Florida 34769

Toll free (888) 835 6739

www.velopexusa.com